

(No Model.)

3 Sheets—Sheet 1.

M. F. DAVIS.

ROW BOAT.

No. 282,853

Patented Aug. 7, 1883.

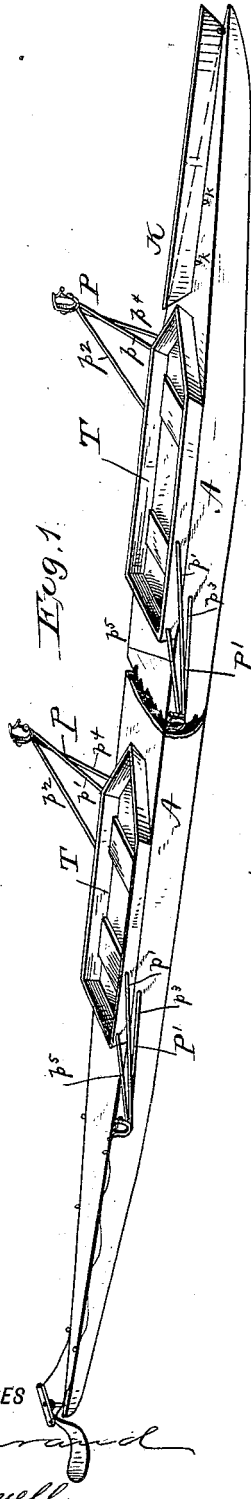

Fig. 1.

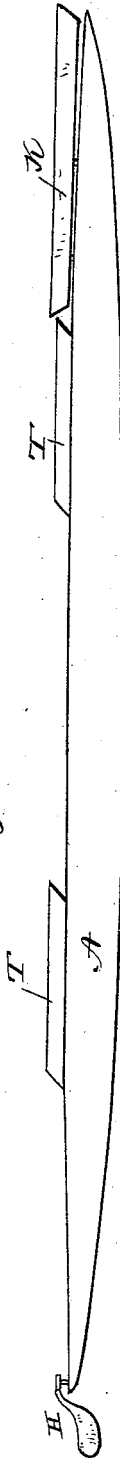

Fig. 2.

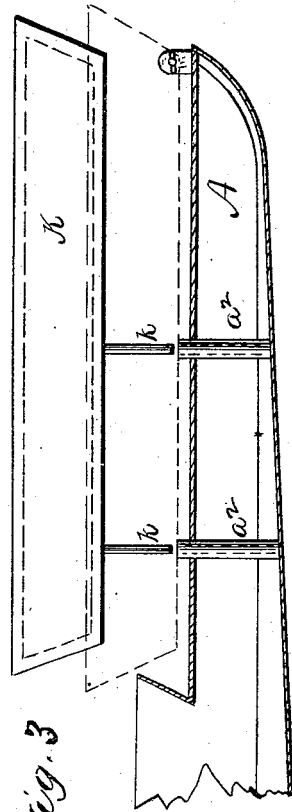

Fig. 3.

WITNESSES

A. L. Curran
George Cornell

INVENTOR

Michael F. Davis
 by *L. Deane*
 his Attorney

(No Model.)

3 Sheets—Sheet 2.

M. F. DAVIS.

ROW BOAT.

No. 282,853.

Patented Aug. 7, 1883.

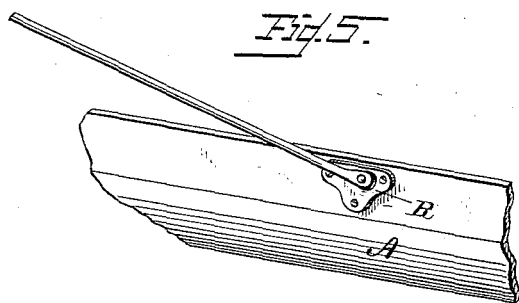
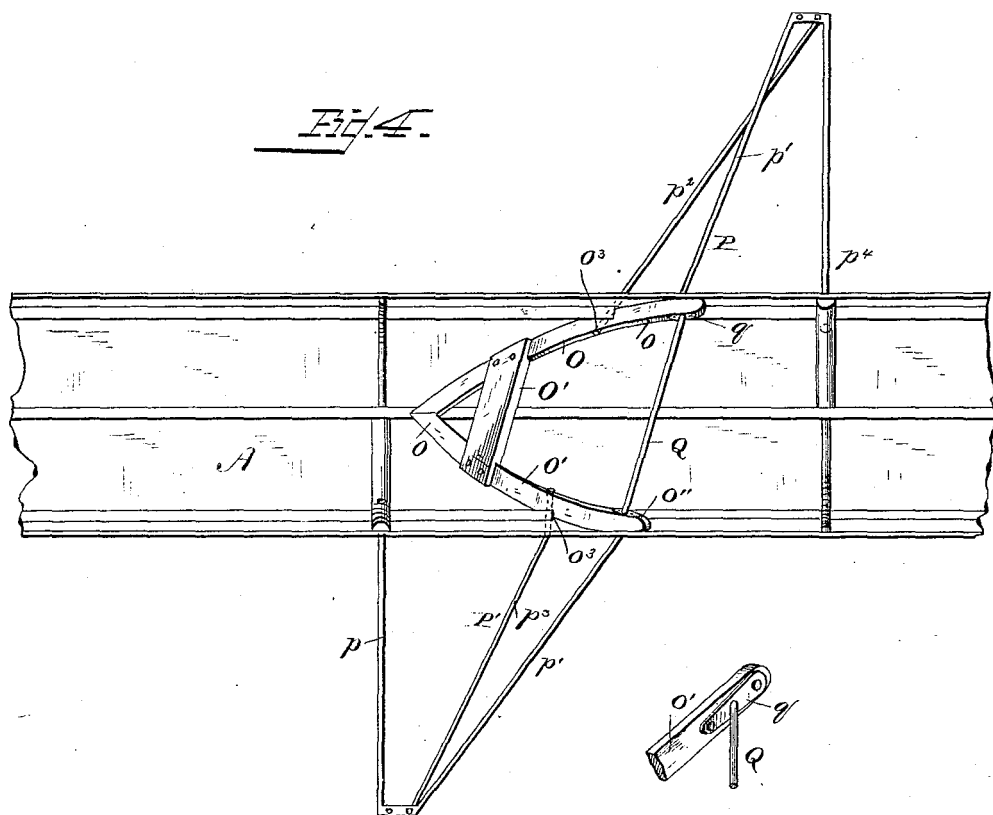

WITNESSES

Francis L. Curran
Amos A. Garner

INVENTOR

Michael F. Davis.
by L. Deane.
his Attorney

(No Model.)

3 Sheets—Sheet 3.

M. F. DAVIS.

ROW BOAT.

No. 282,853.

Patented Aug. 7, 1883.

Fig. 6.

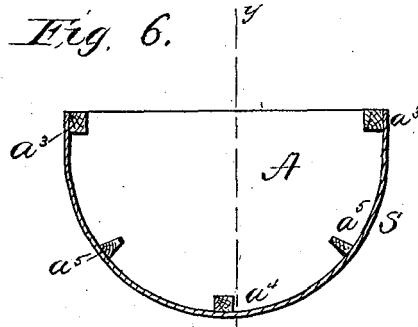

Fig. 7.

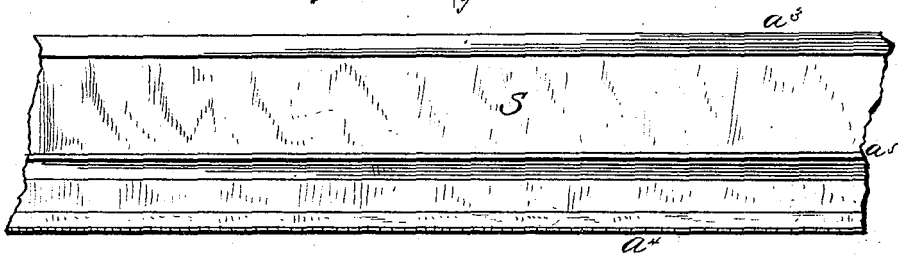
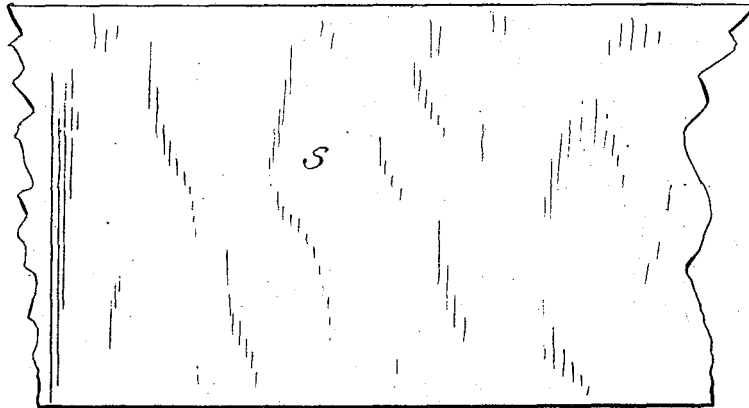

Fig. 8.



WITNESSES

A. L. Curand
George Cornell

INVENTOR

Michael F. Davis.
by L. Deane,
his Attorney

UNITED STATES PATENT OFFICE.

MICHAEL F. DAVIS, OF PORTLAND, MAINE.

ROW-BOAT.

SPECIFICATION forming part of Letters Patent No. 282,853, dated August 7, 1883

Application filed January 31, 1882. (No model.)

To all whom it may concern:

Be it known that I, MICHAEL F. DAVIS, a citizen of the United States, residing at Portland, in the county of Cumberland and State of Maine, have invented certain new and useful Improvements in Row-Boats; and I do hereby declare the following to be a full, clear, and exact description of the invention, such as will enable others skilled in the art to which it appertains to make and use the same, reference being had to the accompanying drawings, and to letters or figures of reference marked thereon, which form a part of this specification.

Figure 1 is a perspective view of the boat broken in two, showing how the crew may be seated in divisions at the fore and aft of the boat; Fig. 2, a side elevation, showing the seats and outriggers separated, so that the crew may be placed over the direct water-support of the boat. Fig. 3 is a detail in section of the wind-balance and boat-bows. Fig. 4 is a plan view, showing the construction and application of one pair of my outriggers; Fig. 5, a detail showing the boat-support. Fig. 6 is a sectional view of a boat covered with veneer, according to the present invention. Fig. 7 is a longitudinal section on line *y y*. Fig. 8 is a plan of a strip of veneer.

This invention relates to improvements in racing-boats; and the novelty consists in the details and particulars, hereinafter fully described and claimed.

In the first place, the construction and arrangement of the outriggers will be described, whereby the opposite outriggers are connected in pairs, so as to prevent strain and also counterbalance each other.

In applying my pairs of outriggers I place in the body of the boat a V-shaped piece of wood or metal, O, made of two pieces, fastened together at the point *o* and firmly secured there on its keelson. The sides *o'* of this piece extend forward and upward at an angle of about thirty degrees, and are firmly bolted to the gunwale at *o³* on each side. The upper ends, *o''*, of this piece O, where they come to the top of the boat, afford on each side the means for attaching the upper rods, *p'*, of the outriggers P P'. To these ends *o''* of the piece O are also secured the plates *q* of the stay Q, which stay passes diagonally across the boat at its upper part, and connects the two upper

ends, *o''*, of the piece O, and thus furnishes the most complete tie or stay for the whole boat. At a suitable point in the lower or aft part of the piece O is secured the truss O'. This is adapted to take the compression-strain in the act of rowing, while the rod Q takes the tensile. This truss O' is placed as near the gunwales as the requirements of the oarsman will permit. The lower outrigger-rods, *p²* and *p³*, are on their respective sides secured to the boat by the same bolt, *o³*, which fastens the side pieces, *o'*, of the V-shaped piece O in position. The right-angled outrigger-rods *p⁴* and *p⁵* are respectively on each side bolted through gunwale preferably.

By the above construction the opposite outriggers are connected in pairs, and the advantage of this construction is that the strain of one outrigger is taken from the boat and communicated to the opposite outrigger or its mate, and each set of forces are made to counterbalance their opposite without bringing any strain on the boat. Heretofore, in the best built boats, a vertical motion existed on the outrigger at the rowlocks, which has been entirely overcome by the present invention. I have only shown three rods, as I desire to secure the lightest construction; but I can use as many more as I please. The plate *q*, which is fixed onto the end of the stay-rod Q, is inclined somewhat to the axis of this rod, so as to fit flush upon the sides *o'* of the piece O. Each piece *q* is considerably long, so as to permit the stay Q to be lowered out of the way of the oarsman's hands; and in order to secure the direct tensile strain, this plate *q* is nearly as long below as above the rod Q, and has bolt-holes at suitable points to allow its being properly secured to said piece O. It is evident, however, that I may have stay or brace rods from Q to the sides *o'* to answer this purpose; but I prefer the plate *q*, now described.

The bolt-support R of the outrigger is secured to the outside of the boat, at the cockpit, and holds the outrigger-bolt firmly in position, preventing its getting out of place or damaging the boat. Heretofore these bolts have been entirely headed in the side of the boat, and the result has invariably been that they would get out of place, as well as "chaw" the boat at this point, and always demand the closest attention.

It is found to be desirable in the more perfect race-boat that the skin and frame shall be so rigid or firm that the boat cannot get out of shape when in use. According to any of the present modes of construction with which I am acquainted it has been found that a boat of the class known as "racing-shells" in the water would be so compressed by its load as to lose its model shape, and even then the shape would be continuously varying, according to the different motions of the oarsman, and thus the boat would get into a very bad condition for attaining the best speed. Therefore light boats were only expected to be strong enough to last for a single race, and even during this race would not hold their lines.

In constructing a boat according to my invention, in addition to the pieces and stays connected with my outriggers, &c., I place on each side, about midway between the gunwale a^4 and keelson a^4 , a supplementary strip or strips, a^5 , which preferably run the whole length of the boat, and over the frame so made by said keelson, gunwales, and strips, and suitably tied together, I place a thin plank or veneer, S , of wood, transversely of its grain, so that the grain shall come athwartships. In Fig. 8 is shown such a sheet cut from a block of wood and all ready to be placed on the boat-frame. By this construction the keelson, supplementary gunwales, and strips are only of the same weight as the keelson and gunwales in boats as formerly made; and thus I produce a light and strong boat, of very durable shape, and that cannot in the water, by any ordinary condition of use, be compressed or have its lines changed.

It is evident that the wood veneer can be laid, as above, over a frame made, as is now the custom, only of the gunwales and keelson, with some strengthening-ribs to hold them together, or even on the gunwales and keelson, the fiber of the wood acting as stays or ribs; but such forms of construction, while they will embody my invention, will not accomplish the results so well or perfectly as the construction above explained. It may sometimes be found of advantage to put a covering of paper, silk, or some suitable substance or material on the inside and outside of the veneer.

Heretofore, in four-oared boats, for example, the crew have been placed in the center of the boat, and as near together as possible. This position or grouping was considered a prime necessity; but I have found it to be radically objectionable, one reason being that in any ordinary boat the center would sag down and the bow and stern be more or less thrown up. In the present boat the oarsmen or crew are placed so that their weight will bear as much as possible along the entire length of the displacement. Thus the load is distributed to the best advantage, insuring a level or even position of the boat on the water. I accomplish all this by separating the crew into divisions, and seat these directly over their water-sup-

port. Thus each division is placed in pairs, so as to insure the application of power at right angles. Each division has preferably but one cockpit, T , to remove unnecessary wind area, and each cockpit is placed as far forward and aft as proper accommodation for each division will allow. This arrangement usually leaves a very considerable unoccupied space amidship, as is shown in Fig. 2, which can be used to advantage by putting in diagonal bracings for the boat. Thus all danger of twisting is reduced to a minimum and the stiffness of the boat assured. The separation of the rowlocks will also give such distance between the blades that the swash from the forward blades will not incommode the blades of the aft division. In the old arrangement of the crew in the center of the boat, the boat would always pitch, and as the crew reached aft to catch a stroke the stern would go under or settle, and then when they finished the stroke the bow would settle. All this is fully obviated by my present arrangement, whereby the bow division prevents the stroke division from settling, and so vice versa.

The above relates more particularly to four-oared boats, but may be used in a double scull, centipede, six, or eight, or any number of pairs.

In making the frame of my boat I may, if desired, use a double keelson—that is, one on each side of the center of the boat's bottom—and, in addition to these, have only the gunwales for longitudinal strips; but, probably, the construction heretofore shown and described is preferable.

It has also been found a great desideratum to have these boats furnished with an appliance on the bows to aid in securing the best control of the boat when the oarsman is rowing; and to this end in the bow of the boat is placed the wind-balance K , on the ridge-pole, so that it will extend nearly from the point of the bow to the cockpit, its lower edge being flush with the deck. It is made preferably of an oblong frame covered with paper and provided with rods k on its under side, which are adapted to fit into sockets a^2 in the bow of the boat. The use of this balance is to counteract the effects of the wind upon the part of the boat aft of the center. This in practice, when the wind is in another direction than dead fore and aft, always throws the stern of the boat around. This balance, by offering an increased surface at the forward part of the boat, causes the equilibrium of the action of the wind on the boat and enables the oarsman, with comparative ease, even in a very high wind, to keep his boat on the desired course.

Having thus described my invention, what I consider new, and desire to secure by Letters Patent, is—

1. The wind-balance K , having rods k , combined with boat A , provided with sockets a^2 , substantially as set forth.

2. A wind-balance or projecting piece, as

K, for the bows of a boat, placed on the ridge-pole, between the cockpit and the point of the bows, substantially as set forth.

5 3. A row-boat having its frame composed of four or more longitudinal strips or timbers, arranged as described, and having a suitable rigid covering, substantially as set forth.

10 4. A row-boat frame covered with a single wood veneer or plank of a single thickness, laid on with its grain athwartship, substantially as set forth.

15 5. A racing-shell, substantially as described, wherein its cockpits are arranged, the one well forward and the other well aft, leaving a considerable clear space in the center of the boat, by which arrangement the oarsmen are located over their relative displacement, and so separated that they shall not affect each other by the swash or other influence of their
20 rowing, substantially as set forth.

25 6. In combination with the boat A, a V-shaped piece, O, having stays *o'* and Q, and secured in place, as described, combined with the outriggers P P on opposite sides, substantially as set forth.

7. A row-boat having outriggers in pairs on opposite sides, so connected, by mechanism substantially as described, as to take all torsion strains from the boat, substantially as described.

30 8. A race-boat provided with outriggers in pairs on opposite sides, and so connected, by mechanism substantially as described, that their brace-rod constitutes tie and supports for the boat-frame, substantially as set forth. 35

9. In a racing-boat, as described, the combination of the outrigger-rod and the piece R, which latter is secured to the side of the boat and affords a support for the bolt which secures the foot of the outrigger-rod, substantially as set forth. 40

In testimony whereof I affix my signature in presence of two witnesses.

MICHAEL F. DAVIS.

Witnesses:

G. W. BALLOCH,
GEORGE CORNELL.