

(No Model.)

2 Sheets—Sheet 1.

W. ROESSLER.
ROWING APPARATUS.

No. 502,467.

Patented Aug. 1, 1893.

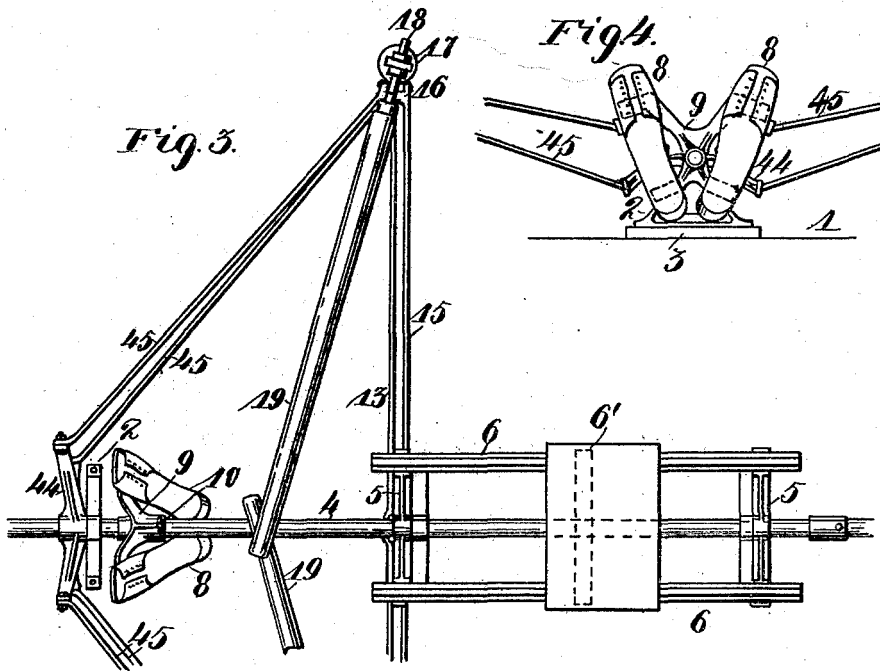
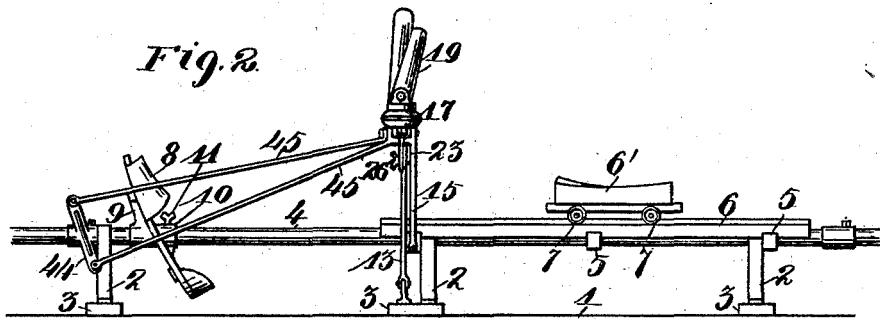
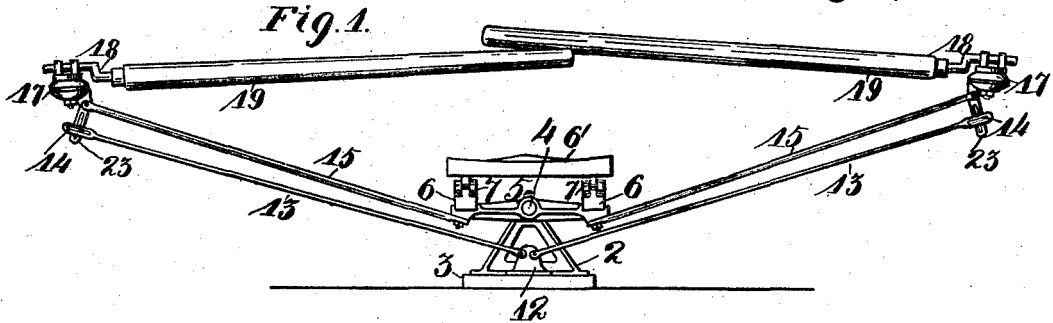

Witnesses

John Ott
Wm. J. Waelder.

Inventor
William Roessler.

By his Attorneys

Keller & Stueck

(No Model.)

2 Sheets—Sheet 2.

W. ROESSLER.
ROWING APPARATUS.

No. 502,467.

Patented Aug. 1, 1893.

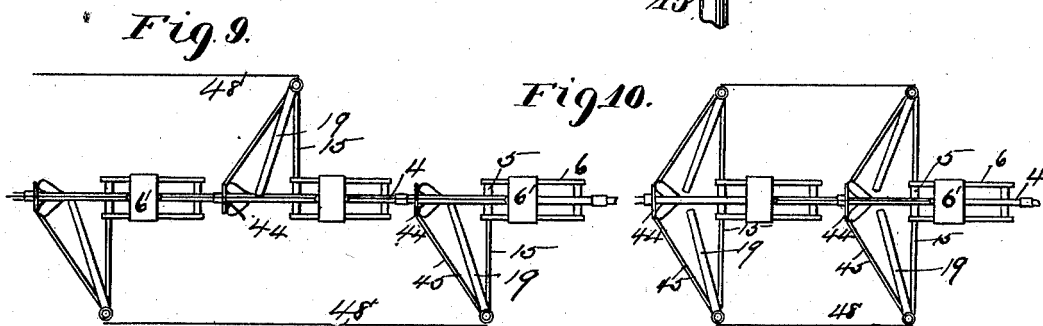
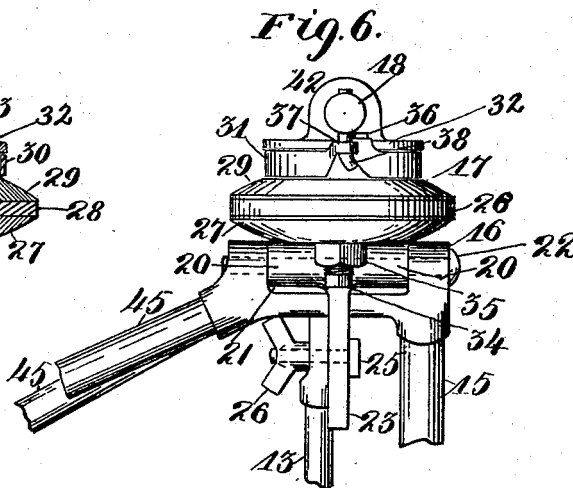
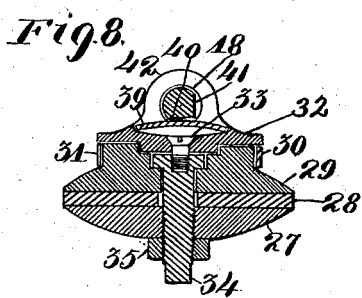
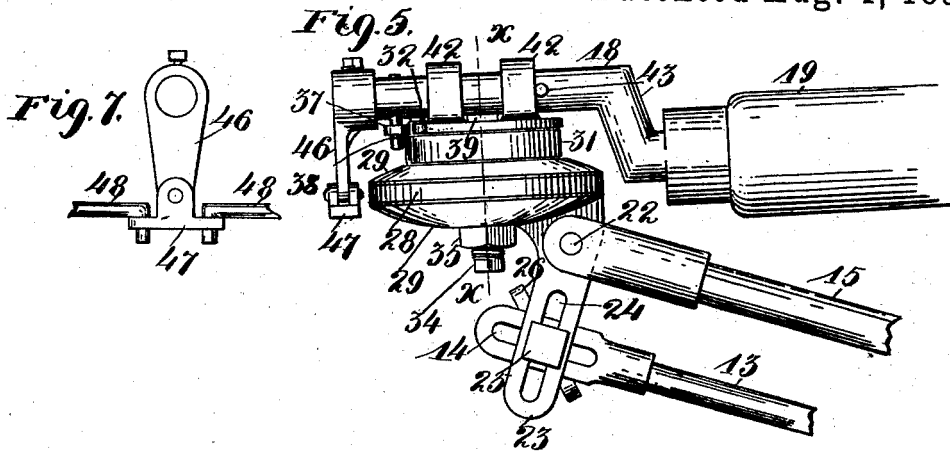

Witnesses

John Ott
Wm J Walker.

Inventor

William Roessler.

By his Attorneys

Keller & Stark

UNITED STATES PATENT OFFICE.

WILLIAM ROESSLER, OF ST. LOUIS, MISSOURI.

ROWING APPARATUS.

SPECIFICATION forming part of Letters Patent No. 502,467, dated August 1, 1893.

Application filed October 15, 1892. Serial No. 448,954. (No model.)

To all whom it may concern:

Be it known that I, WILLIAM ROESSLER, of St. Louis, State of Missouri, have invented certain new and useful Improvements in Rowing Apparatus, of which the following is a full, clear, and exact description, reference being had to the accompanying drawings, forming a part hereof.

My invention relates to rowing apparatus and consists in the novel arrangement and combination of parts more particularly set forth in the specification and pointed out in the claims.

Referring to the drawings Figure 1 is a front elevation of my complete invention. Fig. 2 is a side elevation of the same. Fig. 3 is a top plan view of the device with parts broken away. Fig. 4 is a plan view of the supports for the foot rest with arms attached thereto. Fig. 5 is an enlarged front elevation of the clutch which forms the bearing or lock for the oar with the arms attached thereto broken away. Fig. 6 is a front elevation of a similar view. Fig. 7 is an end view of the crank end of the oar with the ends of the connecting rods attached thereto. Fig. 8 is a vertical section taken on the line $x-x$ of Fig. 5 showing more clearly the construction of the clutch. Fig. 9 is a diagrammatic view showing the application of my device applied to oars disposed singly on either side of the boat; and Fig. 10 is a similar view applied to oars disposed in pairs, or where two oars are operated by one man.

My invention is more especially adapted for training schools where it becomes necessary to train one or more persons for rowing teaching them the necessary grace and ease. It is well known that better results can be obtained in rowing when each person performs the same movements when either pulling or recovering, and in addition, especially when the rowing is done by one person, the oars should be operated, and dipped uniformly at each stroke.

With these objects in view, my invention consists of a seat or seats which are arranged in such a manner as to guide the operator at every stroke causing him always to assume a proper position for rowing.

Referring to the drawings, 1 represents a floor or the bottom of the boat to which my

invention is attached in any well known manner.

2 represents a suitable number of metallic supports which are triangular in shape and mounted upon blocks 3 as best shown in Fig. 1. The upper ends of said supports provide bearings for the shaft 4 allowing the same to be rotated therein. Mounted upon said shaft 4 and keyed to the same are three horizontal supporting pieces 5 upon the ends of which are fixed two guides 6 which are arranged parallel with one another forming tracks upon which the seat 6' moves. The under surface of the seat is provided with wheels 7 which are arranged in pairs and are adapted to be located in position upon the track as best shown in Fig. 1.

8 represents an adjustable foot rest which consists of a casting 9 having a collar 10 formed in the same of such a size as to admit the shaft 4. After the said casting is properly adjusted the same is held rigidly to said shaft by binding screw 11.

12 represents a bracket which is fixed to the block 3 immediately in front of one of the triangular shaped supports 2 and movably attached to the same are the ends of two connecting rods 13. The opposite ends of the said rods are somewhat enlarged or flattened and provided with slots 14 for the purpose of partially adjusting the device in a manner hereinafter described.

Attached to the ends of one of the horizontal pieces 5 or that nearest the bracket 12 are the ends of two connecting rods 15 which are located immediately above the rods 13.

The bearings or locks which I employ for the oars are especially constructed for the purpose and are provided with a clutch the construction and operation of which I shall now proceed to describe.

Referring particularly to Figs. 5 and 6 of the drawings, 16 represents a casting so shaped that the several connecting rods and braces and locks may be readily attached thereto. 17 represents the oar lock or bearing for the shaft portion 18 of the oar 19, the lower portion of which lock is rounded as shown at 20 and of such a size as to be received by the space 21 formed for its reception in the casting 16, and when the parts are united in their proper position a bolt 22 is

passed through the said casting and the rounded portion 20 of the lock allowing the said lock to be moved laterally or in one direction. The said rounded portion 20 is provided with a depending extension 23 and said extension is provided with a slot 24 through which a bolt 25 is passed and through the slot 14 formed in the end of the connecting rod 13. After the parts have been united as above described, a thumb nut 26 is screwed upon the end of said bolt, thereby adjustably securing said parts for the purpose hereinafter specified. Formed with the rounded portion 20 and located upon the same is an enlarged rounded portion 27 having a flat and smooth upper surface upon which surface a leather washer 28 rests. The upper section 29 is also provided with a smooth flat surface which is normally in contact with the opposite side of the washer 28 which renders the sections 27 and 29 movable independently of one another when rowing. The upper portion of the section 29 is provided with a vertical cylindrical surface 30 against which a bow spring 31 is adapted to come in contact. 32 represents a cap which fits snugly upon the top of the section 29 and is held movably in position upon the same by screw 33 passing through the said cap and into the head of a bolt 34, allowing the said cap to be only slightly rotated. The bolt 34 passes through the section 29, washer 28, and the enlarged portion 27 holding the several parts together, premising however that a nut 35 is screwed upon the lower end of said bolt for uniting the several parts and holding the same in proper position. One end of the bow spring 31 is properly formed and attached to the cap 32 by means of a bolt or screw 36, and the opposite end of said spring is provided with a loop 37 for receiving the lower end of a curved pin 38 carried by the shaft portion 18 of the oar. This construction in the device is very important and forms a clutch, the said spring clutching the vertical cylindrical surface 30 of the section 29 when pulling and reduces the work greatly in recovering, that is, in restoring the oars to their original position. Of course it will be understood that the sections 27 and 29 are provided with a proper amount of frictional surface upon the washer 28 by the nut 35, and therefore, when pulling, the upper section 29 is partially rotated by the spring 31, contacting with the said section. When recovering, the shaft portion 18 of the oar is partially turned, which is commonly termed "feathering," causing the rounded or curved end of the pin 38 to move in the looped end of the spring 31, and thus relieve the spring of its tension upon the section 29, the curvature of the pin gradually releasing the tension of the spring as the oar is moved or completely feathered. Formed in the top of the cap 32 is a cavity for the flat spring 39 the ends of which bear against the sides of the cavity and its medium portion yieldingly contacting with one of the flat sides 40 formed

on the shaft portion 18 of the oar 19. The adjacent side of the said shaft 18 is also provided with a flat surface 41 which comes in contact with the medium portion of said spring when recovering or moving the oar back before pulling. By the employment of the spring and the flat surfaces 40 and 41 of the shaft 18 the exact position of the oar can be readily ascertained under all circumstances. The shaft 18 of the oar is angular which assumes the position as shown in Fig. 5 when pulling. The upper portion of the cap 32 is provided with two bearings 42 of such a size as to freely receive the shaft 18 of the oar and allow the same to be turned. 43 represents a pin which is passed through the shaft 18 of the oar which bears against one side of the bearings 42 and operates to hold the said shaft in its proper position. 44 represents a four-cornered casting keyed on the shaft 4 to each corner of which are attached the ends of braces 45 which lead and are attached to one end of the casting 16 in any mechanical manner. (See Fig. 2.)

When the device is used for two or more persons as shown in Fig. 10, cranks 46 are fixed to the ends of the shafts 18, and to the lower ends of said cranks are movably secured bearings 47 having holes for receiving the bent ends of the connecting rods 48 which construction operates to merely couple the parts and cause the operators to row simultaneously. It is also to be noted that the shaft 4 may be of any suitable length and composed preferably of sections coupled together in any well known manner. For laterally adjusting the movement of the locks the adjusting bolt 25 is moved in the slot 24 of the extension 23, and by the employment of the slot 14 formed in the arm 13 the sensitiveness of the device is also accurately adjusted, as best shown in Fig. 1.

From the foregoing description it will be observed that all of the parts comprising the device are secured upon the shaft 4 (excepting the lower ends of the connecting rods 13 which are fixed rigidly to the bracket 12 which is devoid of movement), and consequently when the seat 6' tilts in either direction the oars 19 will be caused to assume a position which will not be true, and cause the oars to dip unevenly. It will therefore be noted that the operator must evenly distribute his weight upon the seat 6' which is a matter of paramount importance to insure the proper results in rowing. Of course when rowing in series the same results will follow, so that the device can be used for training one or more persons as necessity demands. It will be moreover noted that the locks are supported by the braces 45 and 15, and by the adjustable braces 13, by the adjustment of which latter the inclination of the locks may be altered, and that upon the tilting of the seat and parts carried by the shaft 4, say to the right, the brace 13 being secured to a fixed support will so tilt the locks that the handle of the right oar will be thrown down, and the

handle of the left oar thrown up, as is the case in practice when a boat tilts.

Having particularly described my invention, what I claim is—

5 1. In a rowing apparatus, the combination with braces, of oar locks supported thereby, and having extensions formed thereon; a pivoted seat frame; connecting rods secured to the said extension and to a fixed bracket, and
10 connecting rods having their inner ends secured to the seat frame and their opposite ends pivotally secured to the extension of the oar locks, above the first named rods, substantially as described.

15 2. In a rowing apparatus the combination with braces, of oar locks supported thereby and having slotted extensions formed thereon; a pivoted seat frame; connecting rods extensibly secured to the said slotted extension
20 and to a fixed bracket, and connecting rods having their inner ends secured to the seat frame and their opposite ends pivotally secured to the extension of the oar locks above the first named rods, substantially as described.
25

3. In a rowing apparatus, the combination with a suitably mounted shaft, of a seat frame and a crosshead mounted thereon; oar locks having dependent extensions thereon; braces
30 connecting the said crosshead and oar locks, connecting rods secured to the said seat frame and pivotally secured to the said oar locks, and connecting rods having their outer ends secured to the extensions on the oar locks,
35 and their opposite ends secured to a fixed support, substantially as described.

4. In a rowing apparatus, a lock provided with a cavity 39, a spring located in the same, a bearing or bearings formed with or attached
40 to the upper portion of said lock, a shaft 18 forming a part of the oar and adapted to be turned in said bearings, and flat surfaces 40 and 41 formed on said shaft adapted to be

successively brought in contact with the medium portion of said spring, substantially as set forth. 45

5. In a rowing apparatus, a shaft 4 mounted on suitable bearings, pieces 5 fixed to the said shaft supporting guides 6, a bracket 12, connecting rods 13 attached to the said bracket,
50 connecting rods 15 attached to the ends of one of the pieces 5, locks 17 for the oars provided with a rounded extension 20, a casting 16 to which the said extension is movably attached, a slotted extension 23 formed with the said
55 locks for receiving the slotted ends of the connecting rods 13, the said rods 15 being attached to the castings 16 above the slotted connections, and braces 45 connecting the said castings 16 with the casting 44 fixed to
60 the shaft 4, substantially as set forth.

6. In a rowing apparatus a shaft 4 mounted in bearings, a casting 9 adjustable upon said shaft, supporting foot rests 8, pieces 5 fixed
65 to the said shaft supporting suitable guides 6 for the seat, castings 16 having rods 15 attached to the same and to one of the said pieces 5, braces 45 attached to the opposite sides of the said castings 16 and attached to
70 the ends of the casting 44 mounted upon the shaft 4, locks 17 movably secured to the said castings 16, slotted extensions 23 depending from the said locks, a stationary bracket 12, connecting rods 13 movably fixed to the said
75 bracket, slots 14 formed in the opposite ends of the rods 13, and bolts 25 passing through the said slots 14 and slotted extensions 23 of the locks for adjustment, substantially as set forth.

In testimony whereof I affix my signature in the presence of two witnesses. 80

WILLIAM ROESSLER.

Witnesses:

S. T. G. SMITH,

C. F. KELLER.